



**ADJUSTABLE SET POINT AIR PRESSURE SENSING SWITCH KIT**

**APPLICATION**

RFS-4001-047 is a convenient kit containing a general purpose proving switch and two slotted hex mounting screws (#6-3/8"). The RFS-4001-047 switch is designed for HVAC and Energy Management applications and can be used to sense positive, negative, or differential air pressure.

**GENERAL DESCRIPTION & OPERATION**

The plated housing contains a diaphragm, a calibration spring, a snap-acting switch and enclosure cover. The sample line connections located on each side of the diaphragm accept 3/16", 1/4", and 5/16" flexible tubing. Various electrical connections are available. An enclosure cover protects the operator from accidental contact with the electrical components. The enclosure cover has five knockouts for a 1/2" conduit connection.

**MOUNTING (FIG. 1)**

Select a mounting location that is free from vibration. The Model RFS-4001-047 must be mounted with the diaphragm in any vertical plane in order to maintain the specified operating set point. Avoid mounting with the sample line connections in the "up" position.

The standard model is surface-mounted via the two round holes (0.14" dia.) or two of the four slots (3/16" wide) on the zinc-plated strap

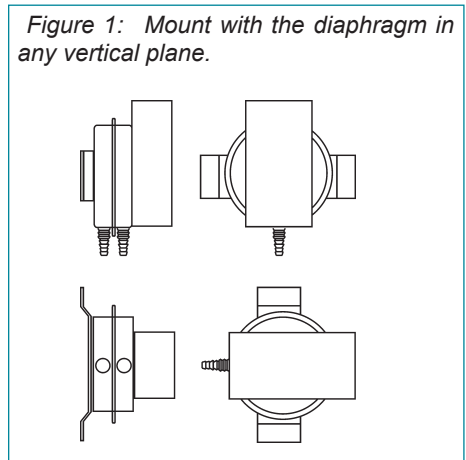

bracket. The mounting holes and slots are 3-7/8" apart. Custom mounting configurations are available.

**AIR SAMPLING CONNECTION (FIG. 2)**

Tri-barbed sample line connectors suitable to accept flexible tubing are situated on either side of the diaphragm as shown in Figure 2. The tri-barbed connectors accept 3/16", 1/4", and 5/16" ID flexible tubing. For sample lines up to 10 feet in length, 3/16" ID tubing is acceptable. For lines up to 20 feet, use 1/4" ID tubing.

Locate the sampling probe a minimum of 1.5 duct diameters downstream from the air source. Install the sampling probe as close to the center of the airstream as possible.

Refer to Figure 2 to identify the **high pressure inlet (H)** and the **low pressure inlet (L)**. Select one of the five application options listed below, and connect the sample lines as recommended.

Figure 2

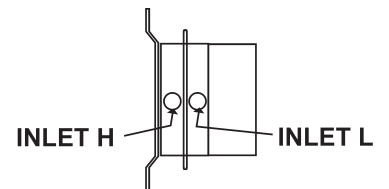

*Positive Only*  
*Lower Negative*  
*Higher Positive*

*Negative Only*  
*Higher Negative*  
*Lower Positive*

Figure 3

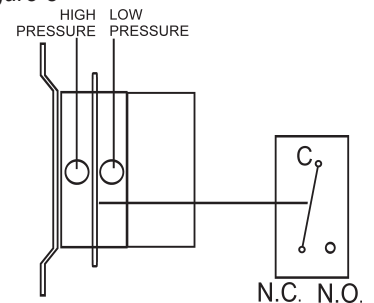

**Positive Pressure Only:** Connect the sample line to inlet **H**; inlet **L** remains open to the atmosphere.

**Negative Pressure Only:** Connect the sample line to inlet **L**; inlet **H** remains open to the atmosphere.

**Two Negative Samples:** Connect the higher negative sample to inlet **L**. Connect the lower negative sample to inlet **H**.

**Two Positive Samples:** Connect the higher positive sample to inlet **H**. Connect the lower positive sample to inlet **L**.

**One Positive and One Negative Sample:** Connect the positive sample to inlet **H**. Connect the negative sample to inlet **L**.

## ELECTRICAL CONNECTIONS (FIGURES 3 & 4)

Before pressure is applied to the diaphragm, the switch contacts will be in the normally closed (NC) position. Wire control and alarm functions as shown in **Figure 4**.

## FIELD ADJUSTMENT

The adjustment range of an **RFS-4001-047** Air Switch is 0.15±0.02" wc to 5.0"wc.

To adjust the set point, turn the adjusting screw counterclockwise until motion has stopped. Next, turn the adjusting screw 5 complete turns clockwise to engage the spring.

From this point, the next eight turns will be used for the actual calibration. **Each full turn represents approximately 0.61" wc.**

**Please note:** To properly calibrate an air switch, a digital manometer or other measuring device should be used to confirm the actual set point.

## SPECIFICATIONS

### MODEL RFS-4001-047

AIR PRESSURE SENSING SWITCH WITH ADJUSTABLE SET POINT RANGE

#### Mounting Position:

Mount with the diaphragm in any vertical plane

#### Standard Set Point Range:

0.15 ±0.02" wc to 5.0" wc.

#### Field Adjustable "Operate Range":

0.17" wc to 5.0" wc.

#### Field Adjustable "Release Range":

0.10" wc to 4.7" wc.

#### Approximate Switch Differential:

Progressive, increasing from 0.05±0.02" wc at minimum set point to approximately 0.3" wc at maximum set point

#### Measured Media:

Air or combustion by-products that will not degrade silicone

#### Maximum Pressure:

½ psi (0.03 bar)

#### Operating Temperature Range:

-40 to 180 °F (-40.0 to 82.2 °C)

#### Life:

100,000 cycles minimum at ½ psi maximum pressure each cycle and at maximum rated electrical load

#### Electrical Rating:

300 VA pilot duty at 115 to 277 VAC; 15 amp noninductive to 277 VAC, 60 Hz.

#### Contact Arrangement:

SPDT

#### Electrical Connections:

Screw terminals with cup washers

#### Sample Line Connectors:

Tri-barb connectors for ⅜", ¼", and ⅝" ID tubing

#### Approvals:

UL, CUL

#### Shipping Weight:

1 lb., approximately

Figure 4

To prove excessive air flow or pressure:

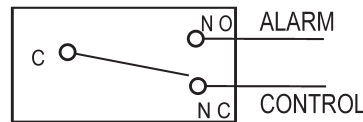

To prove insufficient air flow or pressure:

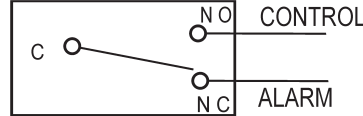

RFS 4001-047 Kit includes:

- Individual Carton with Bar Code Label
- Model RFS-4001-047 Switch
- (2) P/N 27577-037 Mounting Screws, Slotted Hex, #6-⅜"
- Literature

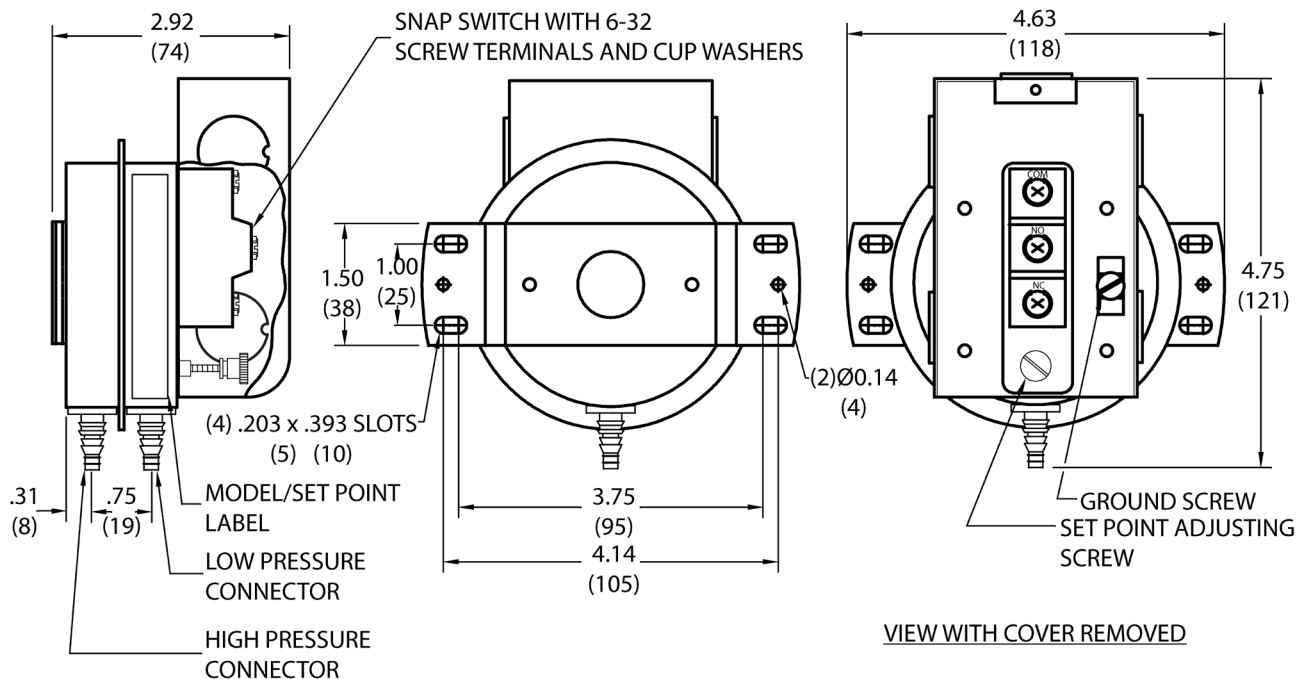
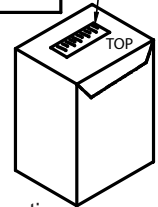

Reference Dimensions in Inches (Millimeters)